

NO	QTY	PART NO	DESCRIPTION	STD SEAL KIT	FKM SEAL KIT	SPRING KIT
1	1	23050010	WASHER	X	X	X
2	1	23312003	SPRING, COMPRESSION			X
3	1	39010012	SEAL, BEVEL, 5/16 X 3/32 X 1/2	X	39V10012	
4	1	39010030	GASKET, COPPER	X	X	X
5	1	82110501	PISTON, CYL, MM, 980			
6	1	39T55009	GASKET, (.451 x .100 x .080)	X	X	X
7	1	39V10029	WIPER, PRESS-IN, (1/4)	X	X	
N/A	N/A	60210105	KIT, SEAL,	NOTED	N/A	N/A
N/A	N/A	6V210105	KIT, SEAL, FKM,	N/A	NOTED	N/A
N/A	N/A	6I210105	KIT, SPRING,	N/A	N/A	NOTED

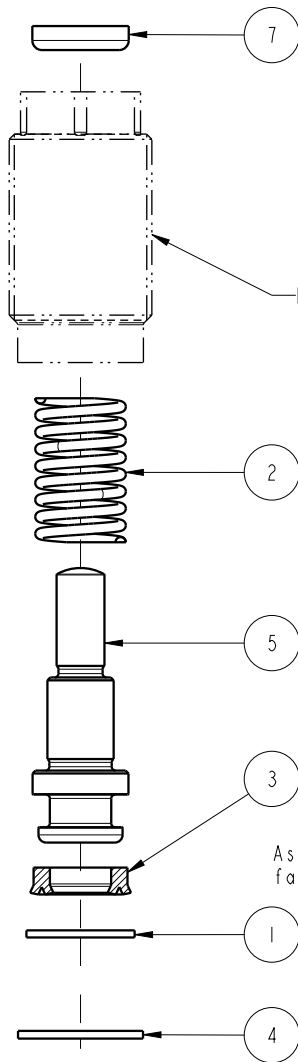

Body -
Not Replaceable

See IS-2100 for machining and installation instructions.

Lubricate all seals with clean hydraulic oil prior to assembly.
DO NOT USE SILICONE BASED LUBRICANTS.

Assemble with the lip side of the seal facing the bottom of the piston.

6 USE ONLY ONE GASKET

INSTALLATION TORQUE:
 -Metal Gasket = 40 ft-lb
 -Composite Gasket = 20 ft-lb
 *Cylinders may need to be re-torqued after a break-in period of 3 weeks or 2,500 cycles for both gasket styles.

Both metal and composite gaskets are supplied. Use only one gasket. The metal gasket is recommended when the cavity seal surface has every smooth finish and is flat and perpendicular to the minor diameter. The metal gasket must be torqued to a higher value, which is more resilient to machining vibrations providing long term sealing. The composite gasket is recommended when the cavity seal surface has a rough surface finish or is not flat.

PARTS LIST



VEKTEK, INC.
1334 E. SIXTH AVE. P.O. BOX 625
EMPORIA, KS. 66801 U.S.A.

ASSEMBLIES AFFECTED

PARTS LIST, ASSY, CYL, CM, 980, .25 STRK, SA, RAD

21-0105-03

21-0105-03F

SIZE
A

PL2101

REV
S

SHEET 1 OF 1

S	3140	RELEASE	BCD	11/9/16
REV	IN ACCORDANCE WITH ECN	EFFECTIVE DATE	REVISED BY	DATE
DRW BY:	JACOB	DRAWING STATUS: Released		
DATE:	10-05-90	PRODUCTION APPROVED FOR RELEASED STATUS ONLY		

FORM FEG035_PL_ASIZE, REV. B

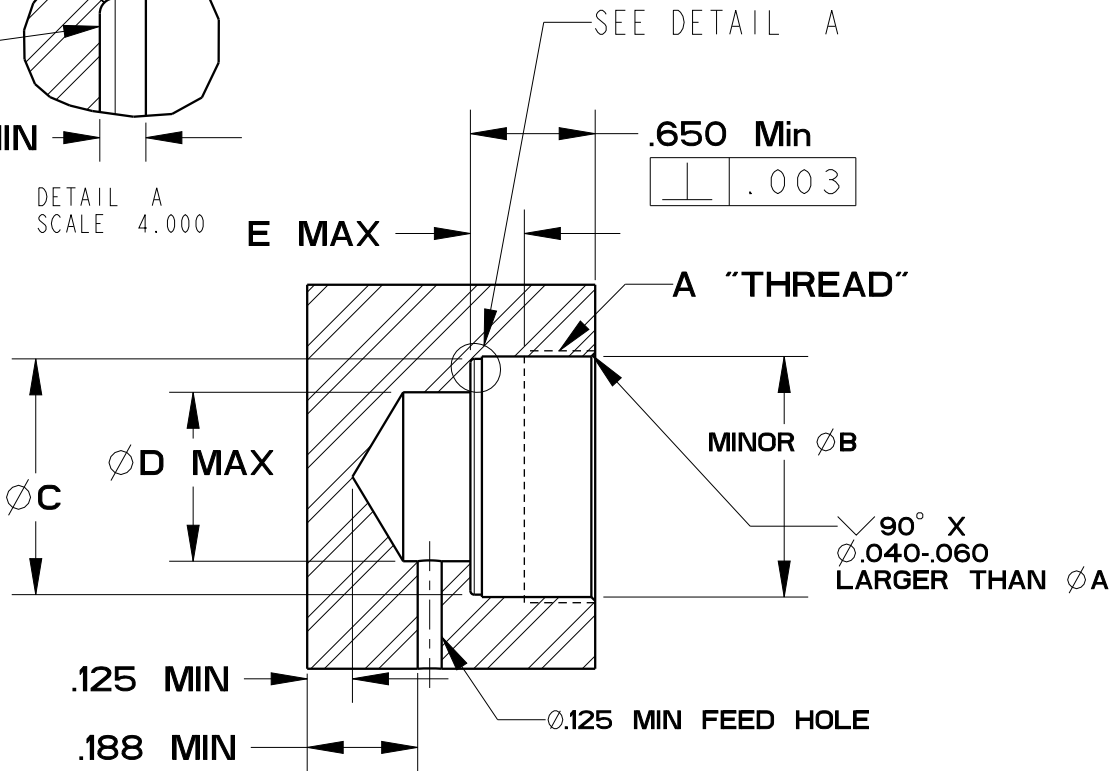
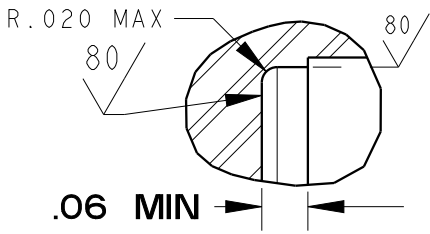

Tighten cylinders with a six point socket only !

Model No.	A	Metal Gasket Torque	Composite Gasket Torque	ØB	ØC	D	E
21-0102-00	3/8-24 UNF-2B	10 ft lb	NA	.335±.003	.325±.005	.13	.100
21-0104-02	5/8-18 UNF-2B	30 ft lb	15 ft lb	.572±.003	.545±.005	.31	.156
21-0105-03	3/4-16 UNF-2B	40 ft lb	20 ft lb	.690±.003	.662±.005	.38	.156
21-0105-04	3/4-16 UNF-2B	40 ft lb	20 ft lb	.690±.003	.662±.005	.38	.156
21-0105-05	3/4-16 UNF-2B	40 ft lb	20 ft lb	.690±.003	.662±.005	.38	.156
21-0105-06	3/4-16 UNF-2B	40 ft lb	20 ft lb	.690±.003	.662±.005	.38	.156
21-0108-04	1 1/16-16 UN-2B	50 ft lb	25 ft lb	1.002±.003	.923±.005	.63	.281
21-0108-05	1 1/16-16 UN-2B	50 ft lb	25 ft lb	1.002±.003	.923±.005	.63	.281
21-0108-08	1 1/16-16 UN-2B	50 ft lb	25 ft lb	1.002±.003	.923±.005	.63	.281
21-0110-04	1 5/16-16 UN-2B	NA	35 ft lb	1.253±.003	1.228±.005	.88	.281

*Cylinders may need to be re-torqued after a break-in period of 3 weeks or 2,500 cycles for both gasket styles.

Instruction Sheet



VEKTEK, INC.
1334 E. SIXTH AVE. P.O. BOX 625
EMPORIA, KS. 66801 U.S.A.

Model number
-See Chart-

Cavity Dimensions
Cartridge Mounted Cylinders

G	3041	RELEASE	BCD	11/9/16
REV	IN ACCORDANCE WITH ECN	EFFECTIVE DATE	REVISED BY	DATE
DRW BY:	VANDALSEM	DRAWING STATUS: Released		
DATE:	04-13-93	PRODUCTION APPROVED FOR RELEASED STATUS ONLY		

SIZE A	IS-2100	REV G
-----------	----------------	----------

FORM FEG041-IS-ASIZE, REV. B

SHEET 1 OF 1